

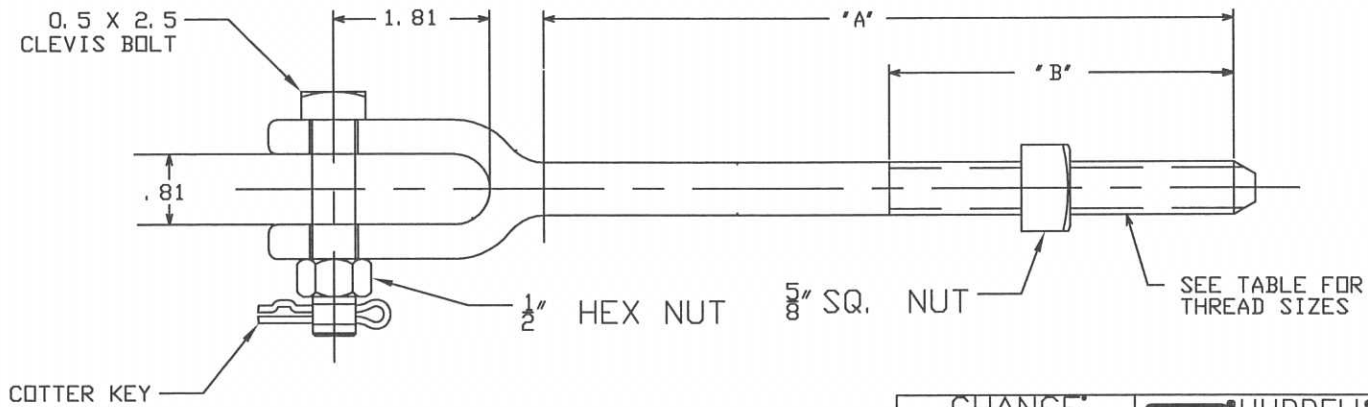

CATALOG NO.	DESCRIPTION	CUT THREAD	"A"	"B"
15808	CLEVIS BOLT 5/8	5/8-11UNC-2A	8	4
15810	CLEVIS BOLT 5/8	5/8-11UNC-2A	10	4
15812	CLEVIS BOLT 5/8	5/8-11UNC-2A	12	6
15814	CLEVIS BOLT 5/8	5/8-11UNC-2A	14	6

-NOTES-

- MAT'L: H. R. STEEL.
- FINISH: HOT DIP GALVANIZE PER ASTM A153 (LATEST REVISION).

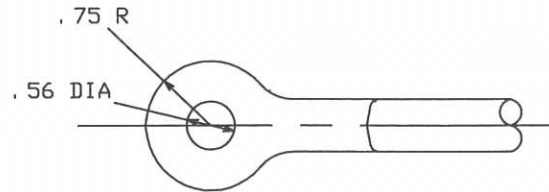

CHANCE TOLERANCE CHART		 HUBBELL POWER SYSTEMS POWER SYSTEMS, INC.	
<small>CONFIDENTIAL: THIS DRAWING AND ITS CONTENTS ARE CONFIDENTIAL AND THE EXCLUSIVE PROPERTY OF HUBBELL POWER SYSTEMS. NO PUBLICATION, DISTRIBUTION OR COPIES MAY BE MADE WITHOUT THE WRITTEN CONSENT OF HUBBELL POWER SYSTEMS. HUBBELL POWER SYSTEMS UNPUBLISHED ALL RIGHTS RESERVED UNDER THE COPYRIGHT LAWS.</small>		TITLE CLEVIS BOLT 5/8	
SIZE	DWG NO.	CAT / PART / ASSY NO.	REV
SB	SA15808	SEE CHART	---
DO NOT SCALE THIS DRAWING	DRN BY WILSON	DATE 02/28/11	SHEET 1 OF 1