

REVISIONS					
NO.	DATE	ECN #	REMARKS	BY	APPD.
1	3-2-05	HJ05-018	CHANGED TAP DEPTH.	JRM	SP

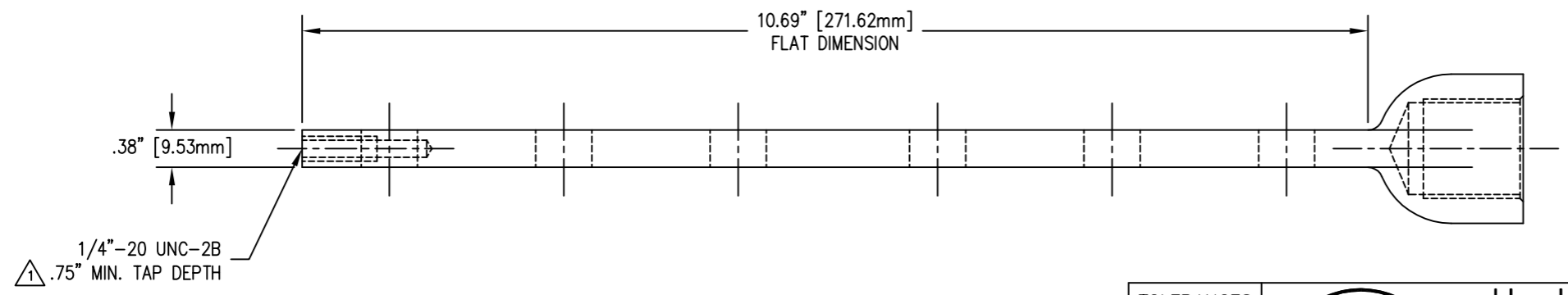
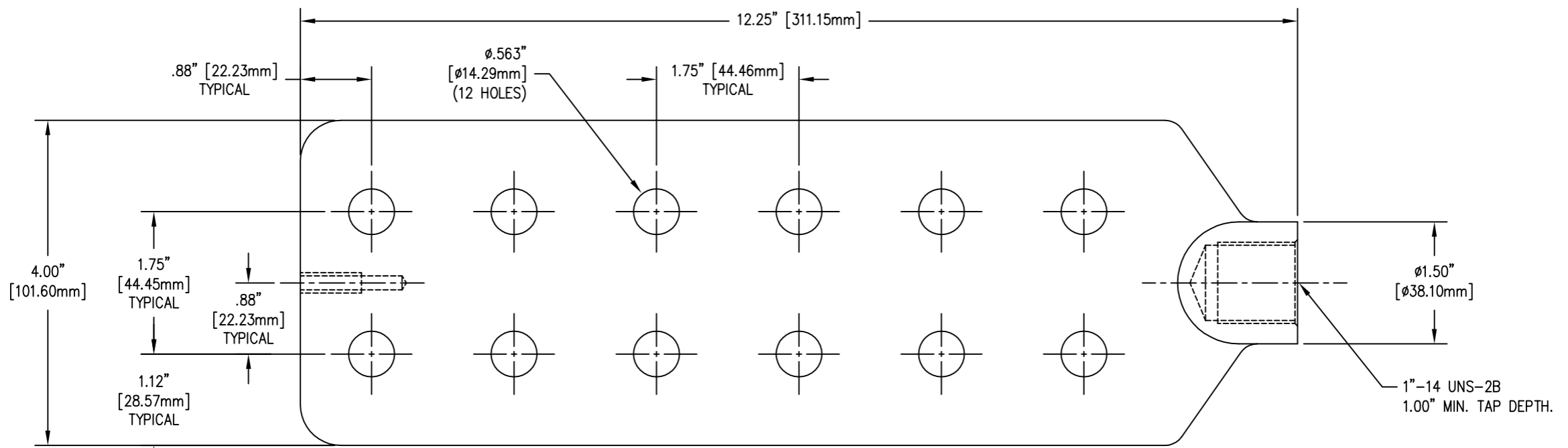

TOLERANCES (EXCEPT AS NOTED) DECIMAL ± .032" / .8mm FRACTIONAL ± ANGULAR ± 2°			H-J ENTERPRISES, INC. 3010 HIGH RIDGE BLVD. HIGH RIDGE, MO. 63049 USA PHONE 1-636-677-3421 FAX 1-636-376-1915		
	SPADE TERMINAL				
	MATERIAL CDA 84400 TIN PLATED				
	DRAWN BY BTD	DATE 9-8-97	CHK'D APP'D SCALE N.T.S.	DRAWING NO. SP3083-001	