

THIS DRAWING IS UNPUBLISHED. RELEASED FOR PUBLICATION 20  
 © COPYRIGHT 20 BY - ALL RIGHTS RESERVED.

LOC	DIST	REVISIONS			
P	LTR	DESCRIPTION	DATE	DWN	APVD
GA	1	K LC20-0036-15 / ECO-15-004322	20MAR2015	JG	BJ

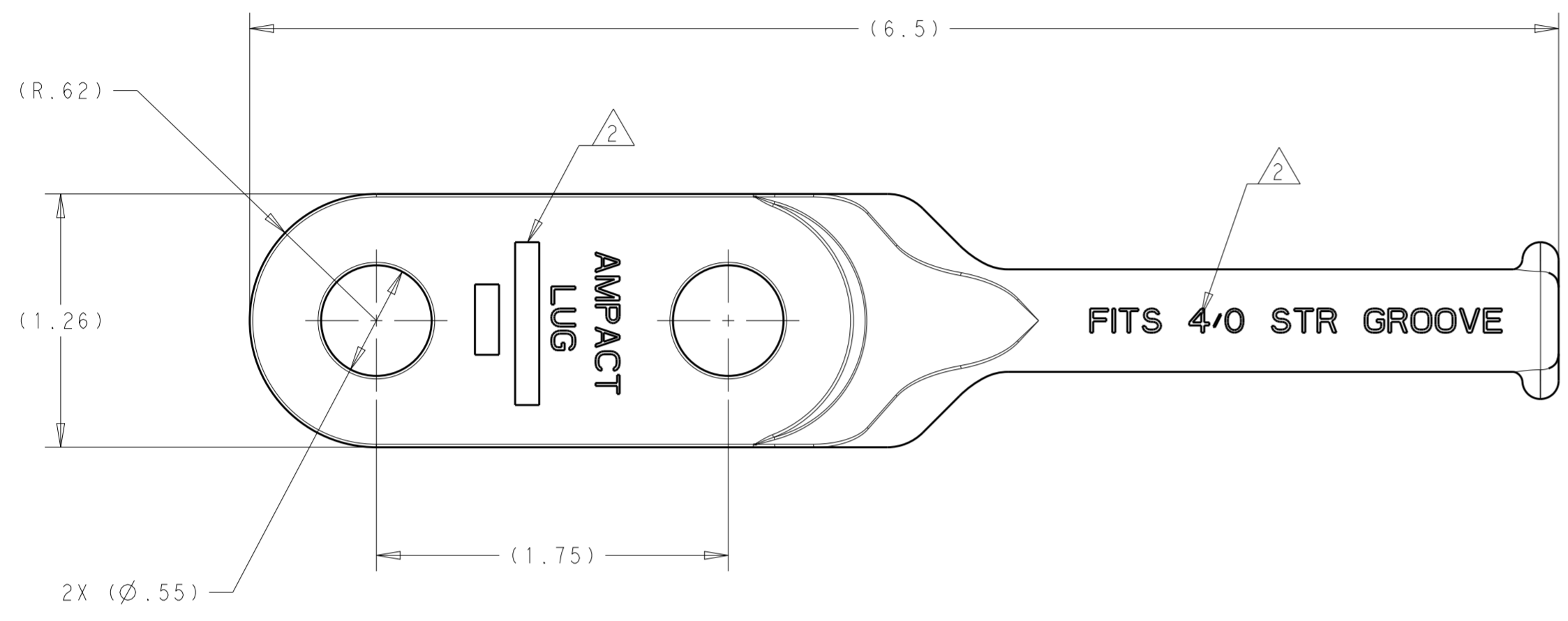

- ACCOMMODATES:  
4/0 STANDARD STRANDED CONDUCTOR GROOVE SIZE.
- MARKING:  
AMPACT LUG  
[PART NO.]  
[CONDUCTOR GROOVE SIZE]
- ALL DIMENSIONS ARE FOR REFERENCE ONLY.

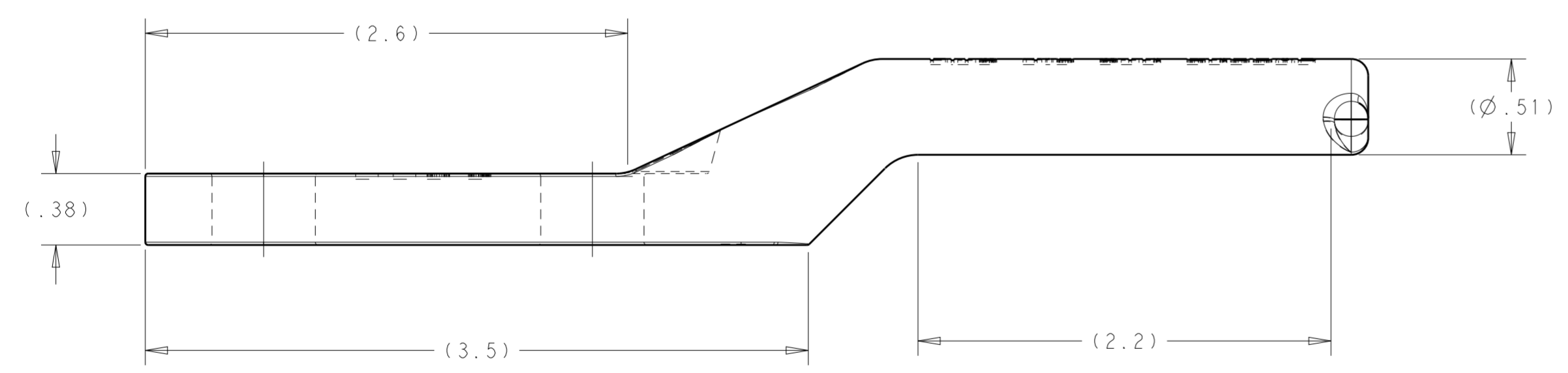

0.73 lbs	602089-3	CU ALLOY	602089-3
0.22 lbs	602089	AL ALLOY	602089
WEIGHT	MARKING $\triangle 2$	MATERIAL	PART NO.

THIS DRAWING IS A CONTROLLED DOCUMENT.		DWN J. GUPPY 12MAR2015	TE Connectivity															
DIMENSIONS: INCHES		CHK D. MURUGIAH 16MAR2015																
TOLERANCES UNLESS OTHERWISE SPECIFIED:		APVD B. JOHNSON 16MAR2015	NAME TERMINAL LUG, 2 HOLE PADDLE, 4/0 STR GROOVE SIZE, AMPACT															
<table border="1"> <tr><td>0 PLC</td><td>±</td></tr> <tr><td>1 PLC</td><td>±</td></tr> <tr><td>2 PLC</td><td>±</td></tr> <tr><td>3 PLC</td><td>±</td></tr> <tr><td>4 PLC</td><td>±</td></tr> <tr><td>ANGLES</td><td>±</td></tr> <tr><td>FINISH</td><td>±</td></tr> </table>		0 PLC	±	1 PLC	±	2 PLC	±	3 PLC	±	4 PLC	±	ANGLES	±	FINISH	±	PRODUCT SPEC -	SIZE A200779	DRAWING NO C-602089
0 PLC	±																	
1 PLC	±																	
2 PLC	±																	
3 PLC	±																	
4 PLC	±																	
ANGLES	±																	
FINISH	±																	
MATERIAL SEE TABLE		APPLICATION SPEC -	WEIGHT SEE TABLE	RESTRICTED TO -														
		CUSTOMER DRAWING	SCALE NTS	SHEET 1 OF 1														
				REV K														