

**SMART NUMBER SYSTEM:**

**GS21 xxx CC x SC**

ADD SC TO END OF PART NUMBER FOR SILICONE COATED ROD

LENGTH "L"  
EX: 012 = 12"  
EX: 144 = 144"

- 1 = ONE SMALL ROLLER
- 1L = ONE LARGE ROLLER
- 2 = TWO SMALL ROLLERS
- 2L = TWO LARGE ROLLERS

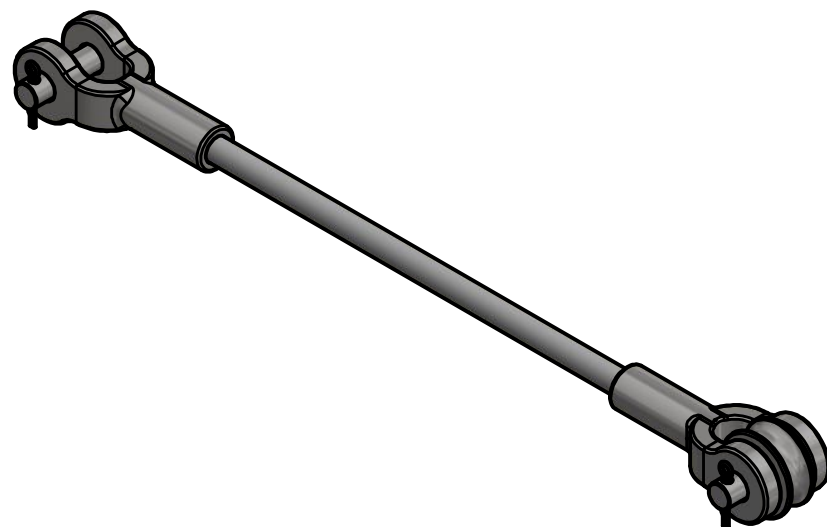

<b>CHANCE</b> ®		<b>HUBBELL</b> ® POWER SYSTEMS, INC.		<b>HUBBELL POWER SYSTEMS, INC.</b>	
CONFIDENTIAL: THIS DRAWING AND ITS CONTENTS ARE CONFIDENTIAL AND THE EXCLUSIVE PROPERTY OF HUBBELL POWER SYSTEMS. NO PUBLICATION, DISTRIBUTION, OR COPIES MAY BE MADE WITHOUT THE WRITTEN CONSENT OF HUBBELL POWER SYSTEMS. HUBBELL POWER SYSTEMS UNPUBLISHED ALL RIGHTS RESERVED UNDER THE COPYRIGHT LAWS.		TITLE <b>GUY STRAIN, 21K CLEVIS-CLEVIS</b>			
SIZE <b>B</b>	CAT / PART / ASSY NO. <b>SEE SMART #</b>	DWG NO. <b>SA_GS21xxxCCx</b>	REV <b>A</b>		
DO NOT SCALE THIS DRAWING	DRN BY RAM	DATE 10/4/18	SHEET 1 OF 1		