

Product Applications

UFO High bay light series can be widely used in Industry, Large commercial facilities, Public, Logistics Center.



Industry
production workshop, assembly line
all kinds of processing sites



Large commercial facilities
Supermarkets, shopping centers
convention and exhibition center
aisle, exhibition hall



Public
Gymnasium, indoor stadium
parking garage



Logistics Center
Warehouses, logistics centers
and so on

Specifications

Size:mm/in

Structure Features

Shell materials: Aluminum & PC.

Finish: Dark Bronze/White

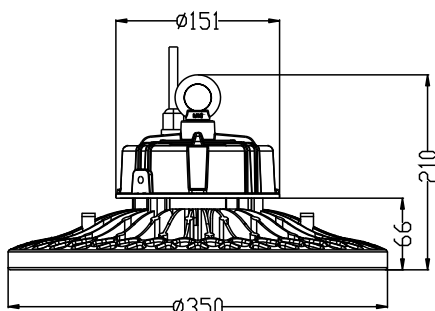

100W-200W

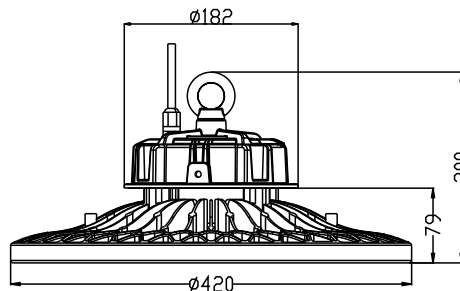

240W

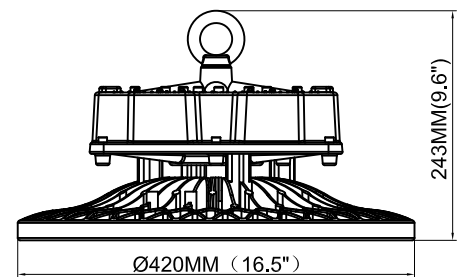

300W

Technical Parameters

Model	Power	Input Voltage	LED Chip	Product Dimension(mm)		Beam Angle	CRI	Light Efficiency	PF	IP Rate
				L	H					
HG-HL-100W-C(DE)	100W	AC100-277V	2835/3030/5050	350	210	60°/90°/120°	Ra>80	>130lm/w	>0.9	IP65
HG-HL-120W-C(DE)	120W	AC100-277V	2835/3030/5050	350	210	60°/90°/120°	Ra>80	>130lm/w	>0.9	IP65
HG-HL-150W-C(DE)	150W	AC100-277V/ AC200-480V	2835/3030/5050	350	210	60°/90°/120°	Ra>80	>130lm/w	>0.9	IP65
HG-HL-200W-C(DE)	200W	AC100-277V	2835/3030/5050	350	210	60°/90°/120°	Ra>80	>130lm/w	>0.9	IP65
HG-HL-240W-C(DE)	240W	AC100-277V/ AC200-480V	2835/3030/5050	420	200	60°/90°/120°	Ra>80	>130lm/w	>0.9	IP65
HG-HL-300W-C(DE)	300W	AC100-277V	2835/3030/5050	420	243	60°/90°/120°	Ra>80	>130lm/w	>0.9	IP65